









PRODUCT UPDATE:

1-1/4" Soft Signage Snap Tensioning System

Ideal for all dye-sublimation and direct printed fabrics

	Part	Part Number	Length	Finish
	1-1/4" Soft Signage Snap Tension Frame	3091N	20'-0"	Mill
	1-1/4" Soft Signage Snap Tension Frame Cover	3094N 3094NA	20'-0" 20'-0"	Mill Clear Anodized
	Soft Signage Grip Strip II	3097	12'-2"	Black
	Soft Signage Tension Frame Z-Clip	3099	12'-0"	Mill
	2 Piece Corner Key	5890		
	1-1/4" Soft Signage Snap Cover Spring	5894		
	Bundled-	B3091N	10'-0"	Mill
	Frame, Cover, and Grip Strip	B3091NA	10'-0"	Clear Anodized

Features & Benefits

- Fast, easy frame assembly.
- No sewing or silicone beads required.
- Snap Cover is available in Mill finish and clear anodized.
- Light weight frame - single and double face.
- Full bleed face.
- Fabric does not need to be cut to exact size.

Pre-Cut Kits Available

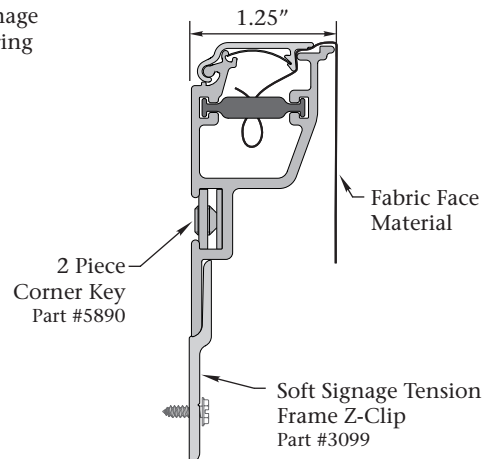
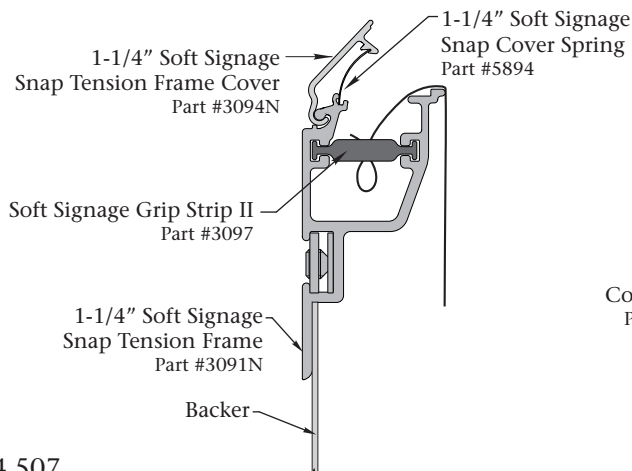
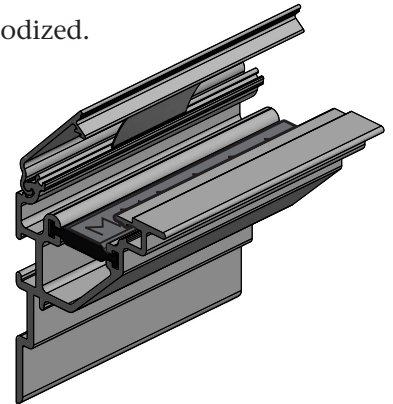

US Patent Number 8,595,966
Canadian Patent Number 2,754,507